

Industrial Electronics

Q.P CODE: 79672

Sem 4/Mechanical/ Choice based/ Dec-19

Q.1)a) Draw and explain V-I characteristics of SCR [5]

[5]

Ans :

The I-V characteristics of SCR is a graph of anode current i on y-axis and anode to cathode voltage plotted on the x-axis as shown in Fig 1

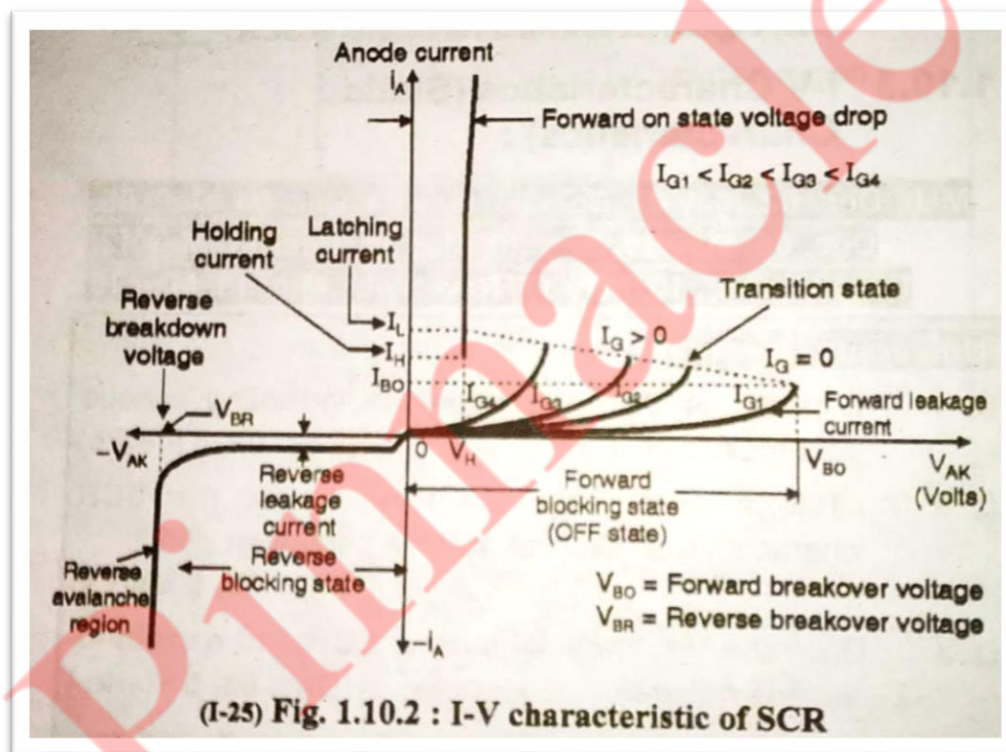

Fig 1

The characteristics in the reverse direction (anode to cathode voltage negative) is similar to a reverse biased diode.

The I-V characteristics can be split into two parts namely the forward characteristics and reverse characteristics.

For small reverse voltage a small reverse leakage current flows until the avalanche breakdown takes place at reverse break over voltage V_{BR} . As soon as the reverse breakdown takes place due

OUR CENTERS :

KALYAN | DOMBIVLI | THANE | NERUL | DADAR

Contact - 9136008228

to avalanche breakdown, a large current flows through SCR whereas the voltage across the device remains constant.

It is dangerous to operate SCR in the reverse breakdown state because it may get damaged due to overheating.

The region from 0 Volts upto V_{ar} volts in which the SCR is reverse biased and non-conducting is called as "reverse blocking state". Reverse blocking means that the SCR is reverse biased and in the non conducting (blocking) state.

Q.1)b) Draw and explain equivalent circuit of an OP-AMP. [5]

Ans: shows the equivalent circuit of a practical OP-AMP includes important values such as A_v , R_i , R_o etc.

Note that A_v, V_d is the equivalent Thevenin voltage source and R_o is the Thevenin equivalent resistance looking back into the output terminal of an OP-AMP.

The value of input resistance R_i , is finite but very high here and that of the output resistance R_o , is non-zero because the OP-AMP is non-ideal.

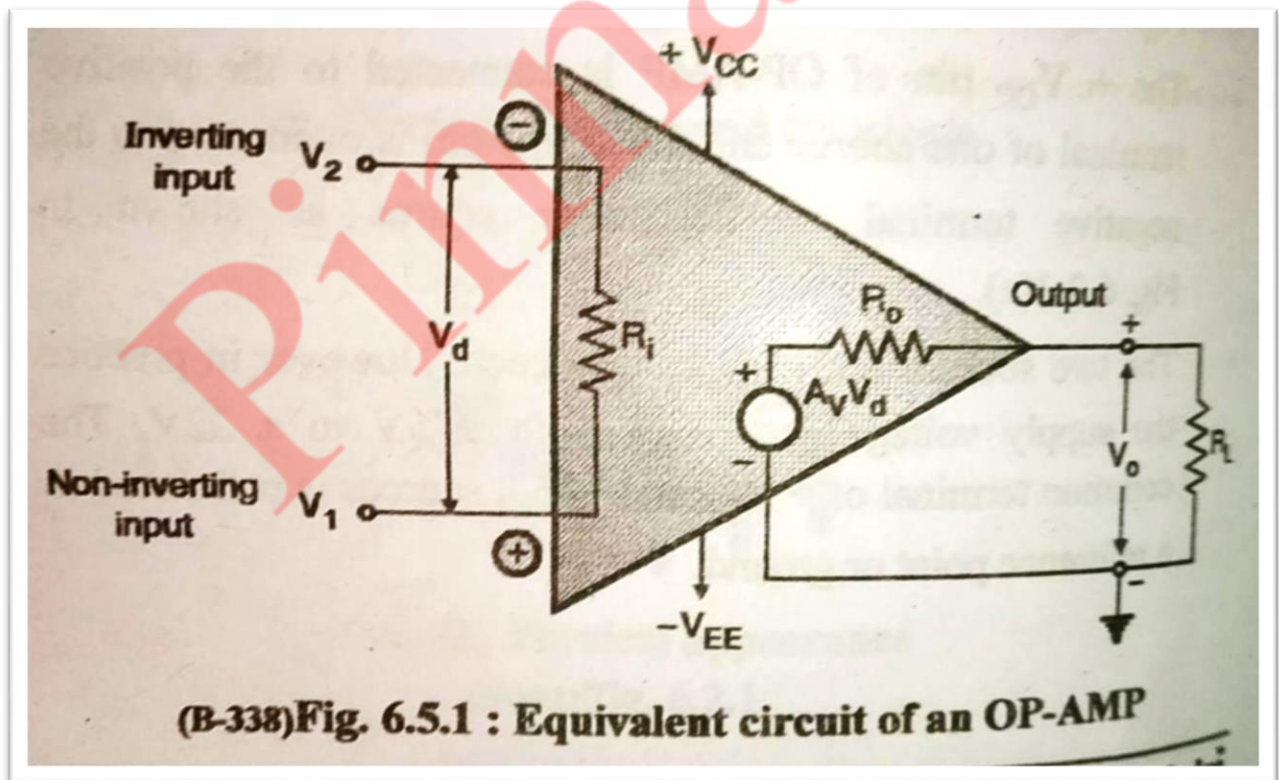

Fig 1

The equivalent circuit of Fig. 1 is made of the differential input resistance R_p , the voltage gain A_v and the output resistance R_o

As will be discussed later, the parameters R_p , A_v and R_o , are called as open loop parameters.

$v_d = v_1 - v_2$ is called as the differential input voltage, and A_v is called as the open loop gain. Hence the output voltage is given by

$$v_o = A_v \times v_d = A_v(v_1 - v_2)$$

V_1 and V_2 , are the voltages at the non-inverting and inverting input terminals of the OP-AMP, with respect to ground.

Since both the input terminals are allowed to be connected to independent potential, with respect to ground, the input side of the OP-AMP is said to be of the Double Ended type. But the output is **single ended type**.

Equation tell us that the OP-AMP responds only to the differential input voltage V_d . That means it produces output voltage which is proportional only to the **difference** between the input voltage and not to the individual input voltages Hence OP-AMPs are also called as **Difference amplifiers**

Repeating Equation

$$V_o = A_v(v_1 - v_2)$$

This shows that the polarity of output voltage depends on the polarity of the differential input signal V_d .

The differential input voltage V_d , is given by.

$$v_d = \frac{v_o}{A_v}$$

This expression gives use of the value of only the differential input voltage V_d , and does not give the individual voltage V_1 and V_2 .

The open loop voltage gain A_v is of very large value. Hence the value of V_d even for maximum output voltage is extremely small. For example, to obtain $v_{o(\max)} = 10\text{V}$ a 741 op amp needs.

$$v_d = \frac{10}{2 \times 10^5} = 50\mu\text{V}$$

Q.1)c) State and prove DeMorgan's theorem. [5]

Ans: The theorem suggested by De-Morgan and which are extremely useful in Boolean algebra are as follows:

Theorem : $AB = A + B$: NAND = Bubbled OR:

This theorem states that the, complement of a product is equal to addition of the complements.

This rule is illustrated in Fig 1. The Left Hand Side (LHS) of this theorem represents a NAND gate with inputs A and B whereas the Right Hand Side (RHS) of the theorem represents an OR gate with inverted inputs. Such an OR gate is called as "Bubbled OR". Thus we can state De-Morgan's first theorem as a NAND operation is equivalent to a bubbled OR operation.

NAND = Bubbled OR

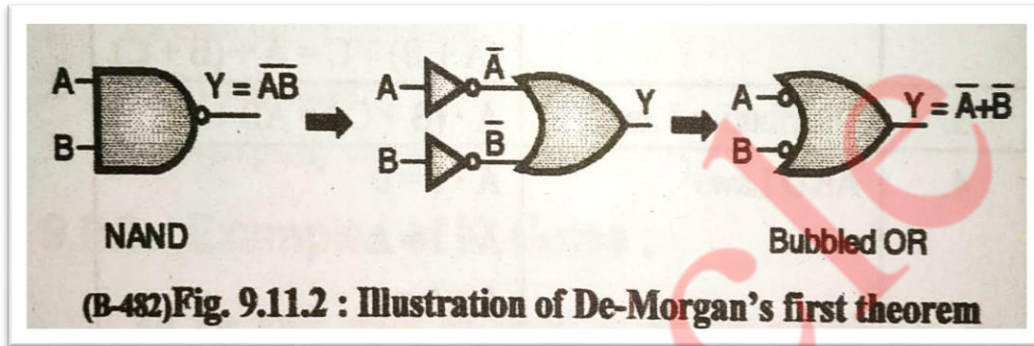

Fig 1

This theorem can be verified by writing a truth table as shown in Fig. 1

A	B	\overline{AB}	\overline{A}	\overline{B}	$\overline{A} + \overline{B}$
0	0	1	1	1	1
0	1	1	1	0	1
1	0	1	0	1	1
1	1	0	0	0	0

LHS $\overline{AB} = \overline{A} + \overline{B}$ RHS

Fig. 9.11.3 : Verification of the theorem $\overline{AB} = \overline{A} + \overline{B}$

Fig 2

Q.1)d) Enlist all important features of logic family circuit. [5]

Ans: Various digital ICs available in market are of different types.

These types are known as "families"

Based on the components and devices that are used inside an IC, the age IC families are named as RTL (Resistor Transistor Logic) TTL (Transistor Transistor Logic), DTL Diode Transistor Logic), CMOS etc.

Fan-in and Fan-out

Fan-in : Fan-in is defined as the number of inputs a gate has. For example a two input gate will have a fan-in equal to 2.

Fan-out : Fan-out is defined as the maximum number of inputs of the same IC family that a gate can drive without falling outside the specified output voltage limits. Higher fan out indicates higher the current supplying capacity of a gate. For example, a fan out of 5 indicates that the gate can drive (supply current to) at the most 5 inputs of the same IC family.

Q.2)Draw and explain slip torque characteristics of AC motor. [7]

Ans : The torque slip or torque speed characteristics of an induction motor is as shown in Fig.1 . The characteristic can be divided into three sections :

1. Forward motoring
2. Regeneration.
3. Plugging

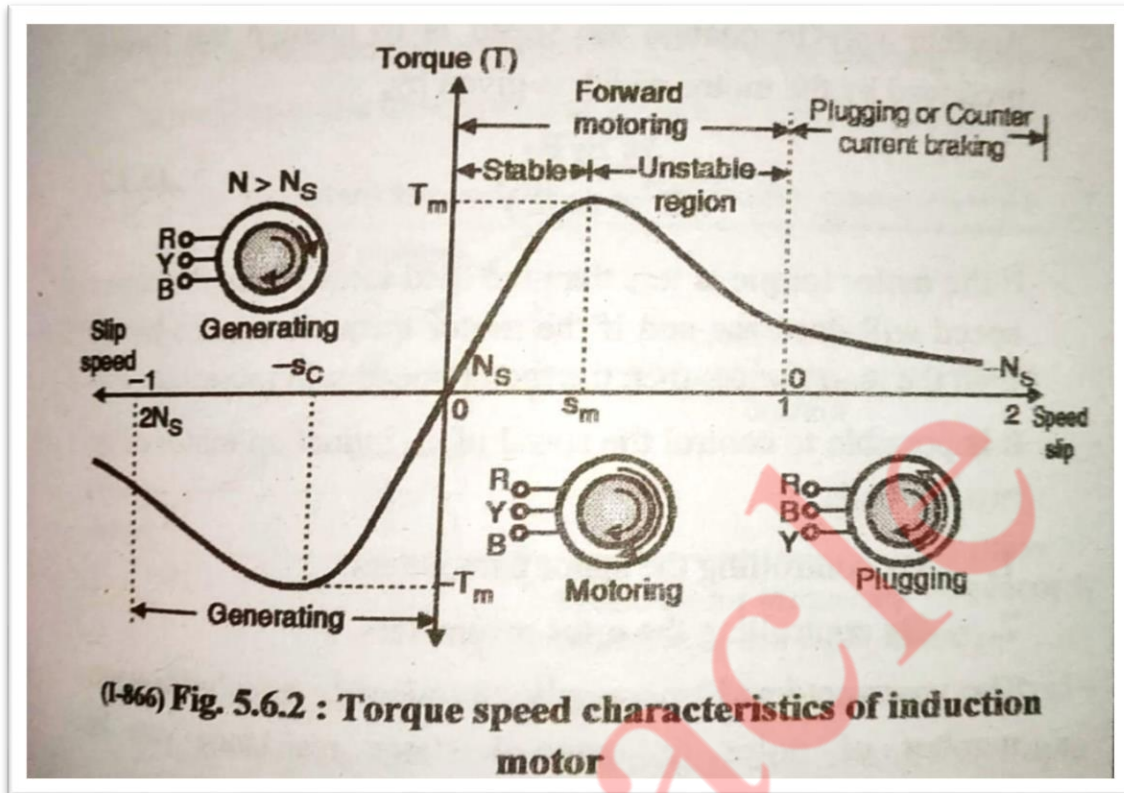

fig 1

As seen from the characteristics, the torque has two maximas one is the stalling torque for the motoring operation and the other for generating operation. The values of slip at which these maximas occur are called as the critical slip "S".

The maximum torque does not depend on the value of rotor resistance R. The maximum torque is also known as "pull out torque" or "breakdown torque".

1. Forward motoring $0 < S < 1$:

In the forward motoring region of the characteristics shown in Fig. the motor rotates in the same direction as that of rotating magnetic field.

The torque produced by the motor is zero at synchronous speed or for $S = 0$. This is because the induced voltage in rotor is zero when $N=N$

The torque increase as the slip increases while the air gap flux remains constant. Once the torque reaches its maximum value T at the critical slip $S= S_e$ the torque decreases, with increase in slip due to reduction in air gap flux.

OUR CENTERS :

KALYAN | DOMBIVLI | THANE | NERUL | DADAR

Contact - 9136008228

2.Plugging or counter current braking ($S > 1$):

As shown in Fig., the motor operates in the plugging or counter current braking mode for value of $S > 1$.

But $s = \frac{N_s - N}{N_s}$ therefore to get values of $S > 1$, N be negative i.e. N , and N must have opposite directions i.e. the RMF (Rotating Magnetic Field) and rotor should rotate in opposite directions. This is achieved by interchanging any two phases of the stator supply.

3. Generating operation (Negative slip)

In order to make slip negative the speed of the rotor (N) should be higher than the synchronous speed (N_s) with both RMF and rotor rotating in the same direction (see Fig.)

In this mode the power is fed back and the machine works as a generator. The regenerative braking (discussed later on) is possible in this region of operation.

The torque slip characteristics is similar to that of motoring but having negative values of torque.

Maximum torque in the generating operation is obtained at $S = -S_c$ The regeneration is possible in the variable frequency drives.

Q.2)b) what is GTO ? Explain switching characteristics of GTO [7]

Ans: The basic structure of the GTO is as shown in Fig.

As seen from the Fig. it is basically a four layer structure similar to a conventional SCR

Fig. shows the circuit symbol for the GTO. As seen from the Fig. GTO is a three terminal device. Gate is control terminal.

Note the two arrows marked on the gate terminal. They indicate that the gate current for GTO can be either positive or negative. (Whereas in SCR the gate current is only positive.)

OUR CENTERS :

KALYAN | DOMBIVLI | THANE | NERUL | DADAR

Contact - 9136008228

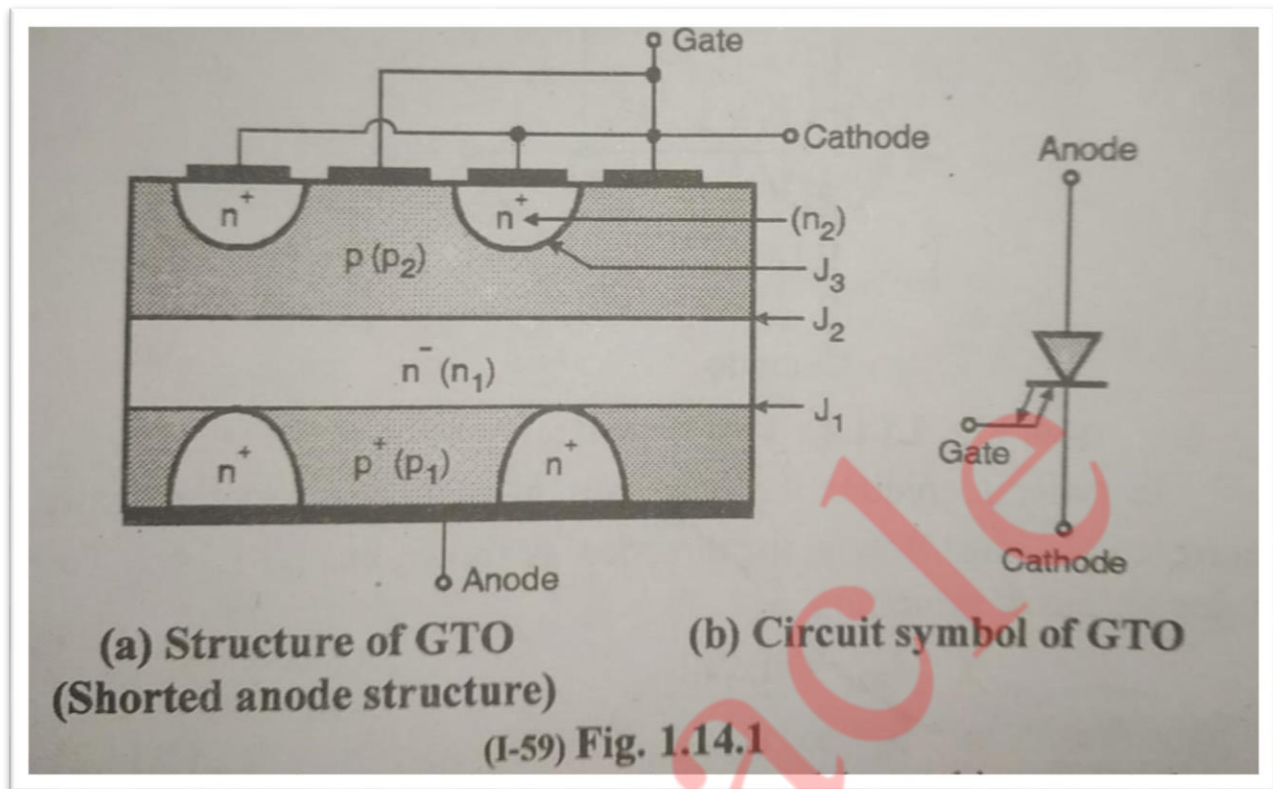

fig 1

Important characteristics of GTO

The forward (positive) gate current required to turn on a GTO is much higher than that of a conventional SCR of identical ratings.

The turn on time of GTO (typically 1 S) is similar to that of a conventional SCR but the turn off time of GTO is much less typically 1 us) than the turn off time of a conventional SCR (typically 5 to 30 S). Thus GTO can be used at a much higher switching frequency.

Applications of GTO

1. Inverters.
2. DC motor drivers.
3. Uninterruptible power supplies.

OUR CENTERS :

KALYAN | DOMBIVLI | THANE | NERUL | DADAR

Contact - 9136008228

Q.2)c) compare DIAC and TRIAC.

[6]

Ans:

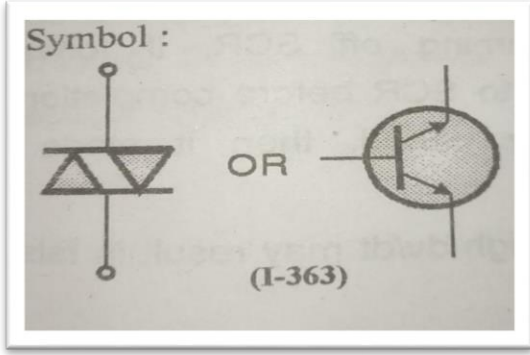
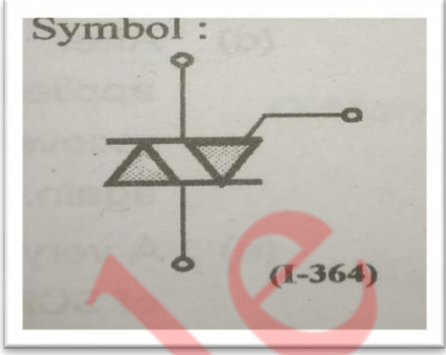
Sr.No	DIAC	TRIAC
1.		
2.	It is a two terminal device	It is a three terminal device
3.	Break over voltage cannot be controlled	Break over voltage cannot be controlled by adjusting the gate current.
4.	Diac is a low power device	Triac is a high power device
5.	It is used as a triggering device for the triac.	It is used in application like fan control light dimmer etc.
6.	The reliability is less	Reliability is more

Q.3)a) Draw and explained full controlled rectifier with R load. Draw waveforms. [7]

Ans : The single phase full converter consists of four thyristors SCR, to SCR, connected in the bridge configuration driving a resistive load as shown in Fig.

These four thyristors can be divided into two groups each consisting of two SCRs. The full converter circuit is being operated on single phase ac mains as shown in Fig.

Mode I ($\alpha < \omega t < \pi$)

In the positive half cycle of the input ac mains voltage the thyristors SCR, and SCR, are forward biased and hence can be turned on at the desired value of firing angle

As soon as the thyristors SCR, and SCR, are turned on at ac mains gets connected across the load as shown in Fig.

The load voltage is thus equal to the instantaneous supply voltage. The current flows from L through SCR, load R, SCR, back to N as shown.

The load current is positive and has the same shape as that of ac mains input voltage. The load voltage and load current are in phase.

OUR CENTERS :

KALYAN | DOMBIVLI | THANE | NERUL | DADAR

Contact - 9136008228

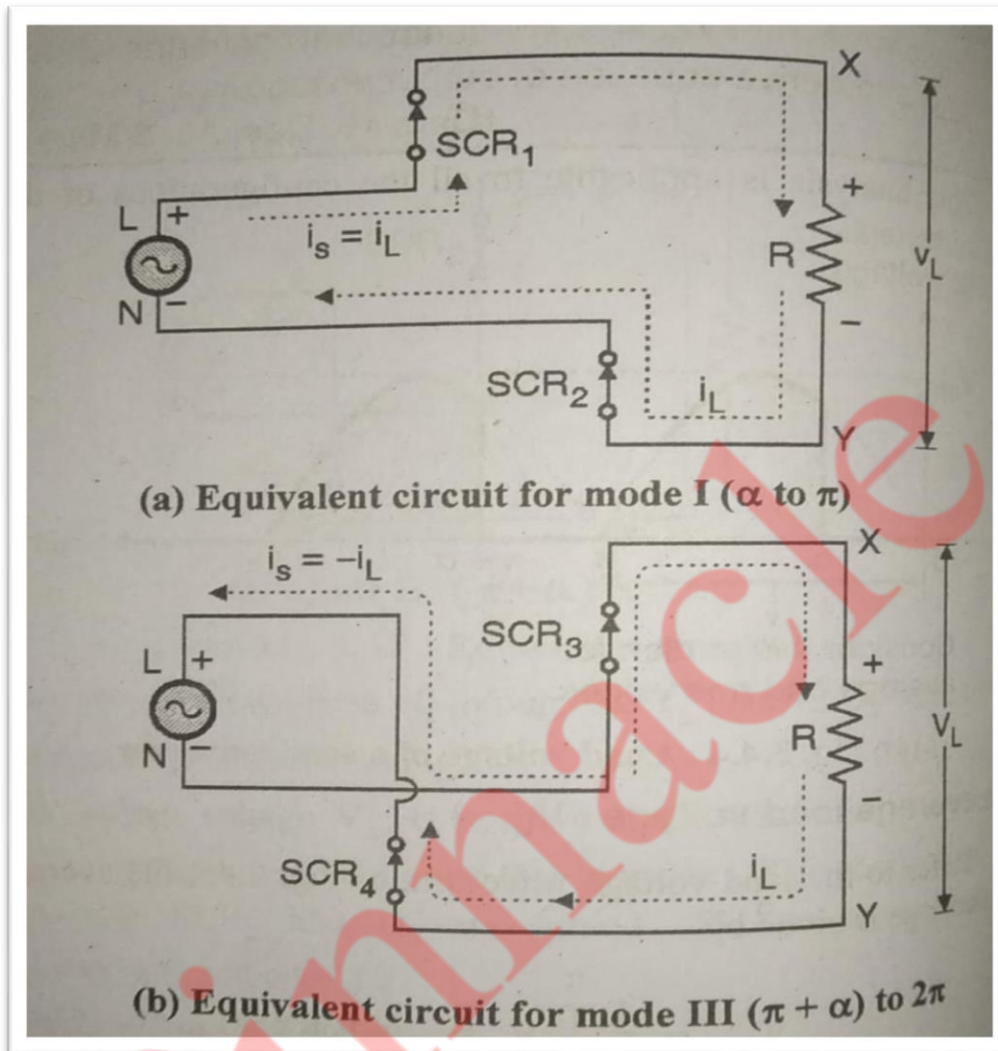

Fig 1

Mode II (π to $\pi + \alpha$) :

All the SCRs remain off during the period a to $a + a$. The load voltage and load current is zero during this mode of operation

Mode III ($(\pi + \alpha) < \omega t < 2\pi$):

The ac input voltage becomes negative after r . This makes SCR, and SCR forward biased.

These SCRs are turned on at $(n a)$ in the negative half cycle of input ac mains voltage. The equivalent circuit of this mode is as shown in Fig. 3

The current now flows from N through SCR3, load R, SCR, back to L as shown in Fig.

OUR CENTERS :

KALYAN | DOMBIVLI | THANE | NERUL | DADAR

Contact - 9136008228

Thus the load voltage still remains positive (X is positive w.r.t. Y) and equal to instantaneous supply voltage. The load current is also positive but the supply current i , changes its direction and becomes negative.

The SCR, and SCR, continue to conduct during the entire negative half cycle i.e. from $(+\alpha)$ to 2π .

At $t =$ also zero and the thyristors SCR, and SCR, are turned off at 2π the supply voltage goes to zero, the load current 2π due to Natural Commutation.

Mode IV ($0 < \omega t < \alpha$):

During this interval, all the SCRs remain off. The load voltage and load current is zero during this mode of operation.

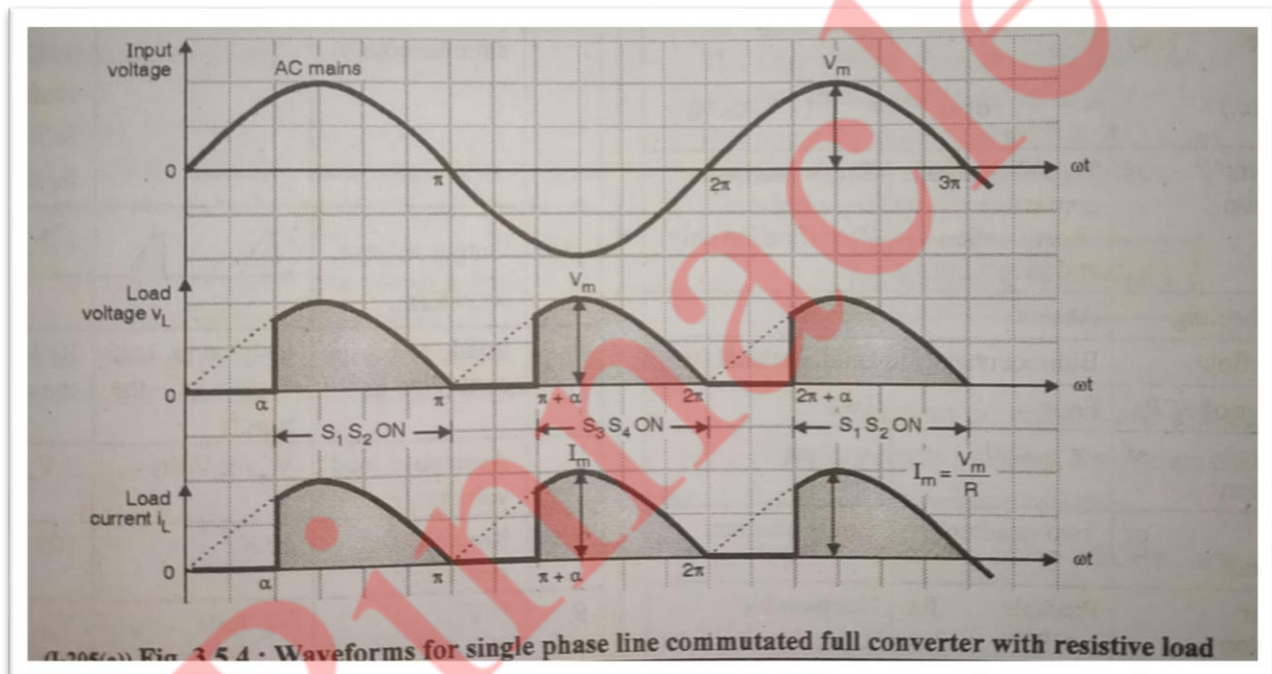

fig 2

Q.3)b) Explain with neat diagram MSP 430 architecture. [7]

Ans : The different units of the MSP430 are described below:

Oscillator is used to generate the clock signals for the internal units of the microcontroller.

CPU of 16-bit with 16-bit registers is present in the microcontroller. This is capable of performing 16-bit operations simultaneously.

Flash memory can be programmed via the JTAG port, the bootstrap loader, or in-system by the CPU. The CPU can perform single-byte and single-word writes to the flash memory.

Watchdog timer. The primary function of the watchdog timer (WDT) module is to perform a controlled system restart after a software problem occurs. If the selected time interval expires, a system reset is generated.

USARTO: The MSP430 devices has one hardware universal synchronous/asynchronous receive transmit (USART) peripheral module that is used for serial data communication

The USART supports synchronous SPI (3 or 4 pin) and asynchronous UART communication protocols, using double-buffered transmit and receive channels.

Timer. Timer is a 16-bit timer/counter with three capture/compare registers. Timer can support multiple capture/compares, PWM outputs, and interval timing Timer also has extensive interrupt capabilities.

Comparator. The primary function of the comparator module is to support precision slope analog-to-digital conversions, battery-voltage supervision, and monitoring of external analog signals.

ADC12: The ADC12 module supports fast, 12-bit analog-to digital conversions. The module implements a 12-bit SAR core, sample select control, reference generator and a 16 word conversion-and-control buffer.

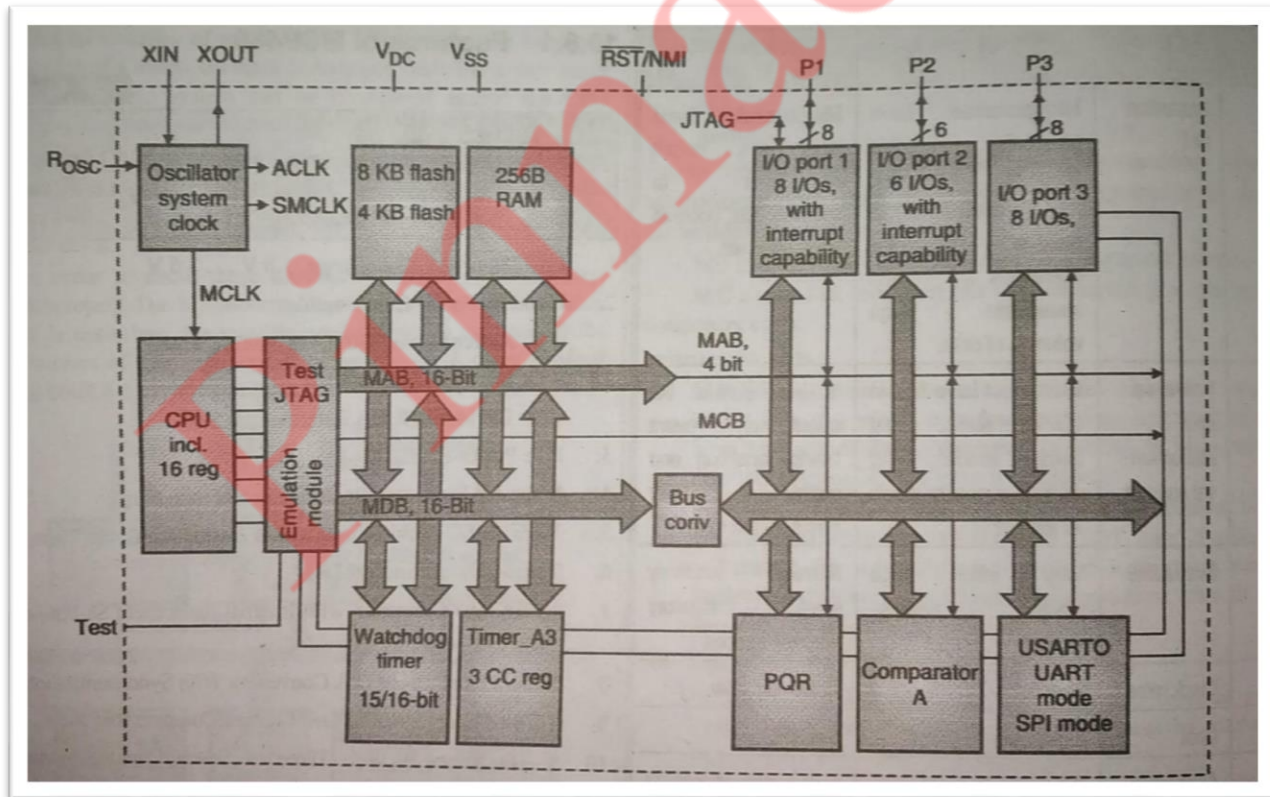

fig 1

The conversion-and-control buffer allows up to 16 independent ADC samples to be converted and stored without any CPU intervention.

DAC12: The DAC12 module is a 12-bit, R-ladder, voltage output DAC. The DAC12 may be used in 8 or 12-bit mod and may be used in conjunction with the DMA controller.

When multiple DAC12 modules are present, they may be grouped together for synchronous operation.

Registers of MSP430: MSP430 has 16 general purpose registers of 16-bit each. These registers are named from R0 to R15. Some of them are R0 to R3 also have some special functions namely the program counter, stack pointer, status register and a constant generator respectively as shown in the figure below. The other registers viz R4 to R15 are just 16-bit general purpose registers.

Program counter holds the address of the next instruction to be executed by the microcontroller.

Stack pointer points to the top of stack. Stack is used to store data for some temporary time. It is also used to store the return address when a function is called. Stack pointer is word aligned i.e. the LSB is always '0'. The storage of data to stack is called as push operation, while retrieval of data from stack is called as pop operation.

When a data is pushed to the stack, the stack pointer first decrements and then the data is stored in the location pointed by the stack pointer.

When a data is popped from the stack, the data is first read and then the stack pointer is incremented.

The stack is a reserved area of the memory where temporary information may be stored. A n-bit stack pointer is used to hold the address of the most recent stack entry. This location which has the most recent entry is called as the top of the stack.

When the information is written on the stack, the operation is called PUSH. When the information is read from the stack, the operation is called POP. The stack works on the principle of Last In First Out or First In Last Out. The microprocessor stores the information/data like stacking plates. Fig. 1 shows stacked plates. If we want to remove the first stack plate, then we have to remove all the plates above the first i.e. we have to remove the fourth plate, third plate, second plate and then finally the first plate.

This indicates that the first plate pushed onto the stack is the last one to be popped from the stack. This operation is called as First In Last Out (FILO).

Q.3)c) Draw and explain second order pass filter. [6]

Ans : Second Order Filters which are also referred to as VCVS filters, because the op-amp is used as a Voltage Controlled Voltage Source amplifier, are another important type of active filter.

design because along with the active first order RC filters we looked at previously, higher order filter circuits can be designed using them.

In this analogue filters section tutorials we have looked at both passive and active filter designs and have seen that first order filters can be easily converted into second order filters simply by using an additional RC network within the input or feedback path

. Then we can define second order filters as simply being: “two 1st-order filters cascaded together with amplification”.

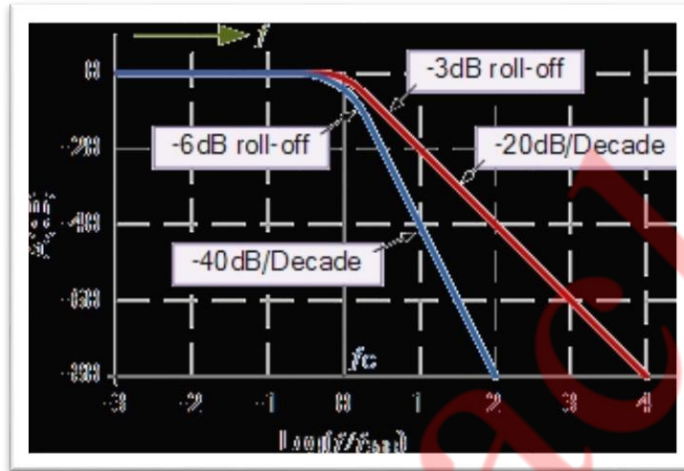

Fig 1

This second order low pass filter circuit has two RC networks, $R1 - C1$ and $R2 - C2$ which give the filter its frequency response properties.

The filter design is based around a non-inverting op-amp configuration so the filter's gain, A will always be greater than 1. Also the op-amp has a high input impedance which means that it can be easily cascaded with other active filter circuits to give more complex filter designs.

The normalised frequency response of the second order low pass filter is fixed by the RC network and is generally identical to that of the first order type.

The main difference between a 1st and 2nd order low pass filter is that the stop band roll-off will be twice the 1st order filters at 40dB/decade (12dB/octave) as the operating frequency increases above the cut-off frequency f_c , point as shown.

Q.4)a) Draw circuit diagram and waveforms of single phase full bridge inverter with R load. [7]

Ans : The single phase full converter consists of four thyristors SCR, to SCR, connected in the bridge configuration driving a resistive load as shown in Fig.

These four thyristors can be divided into two groups each consisting of two SCRs. The full converter circuit is being operated on single phase ac mains as shown in Fig.

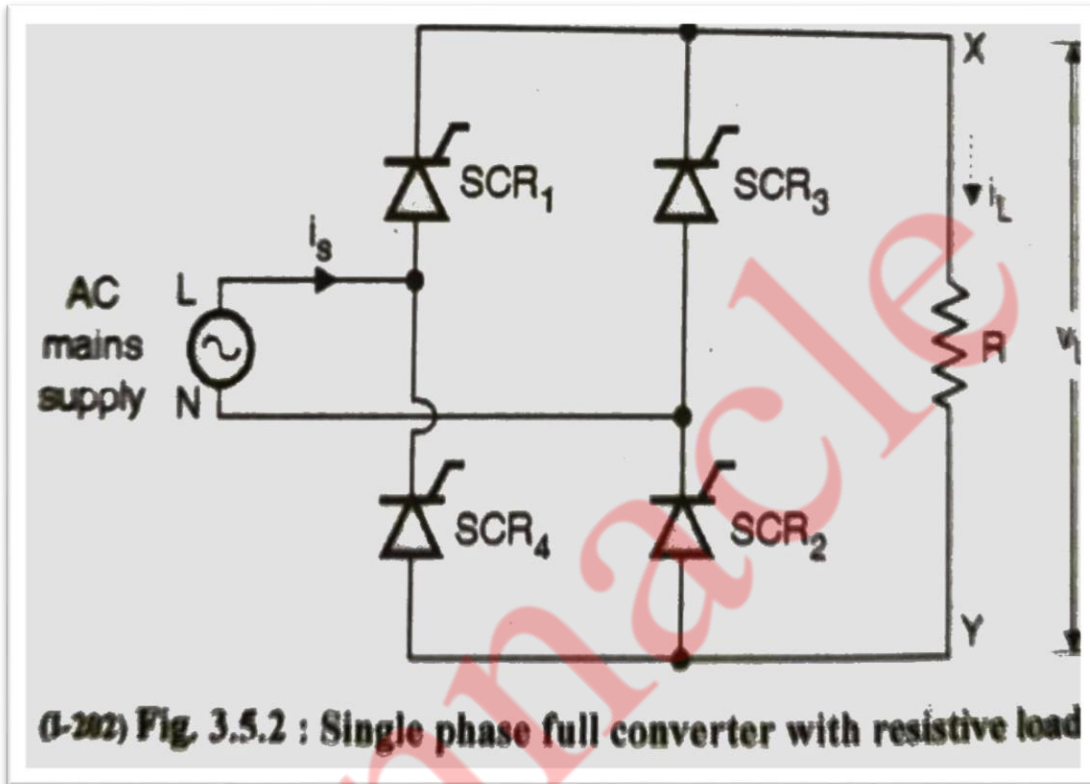

Fig 1

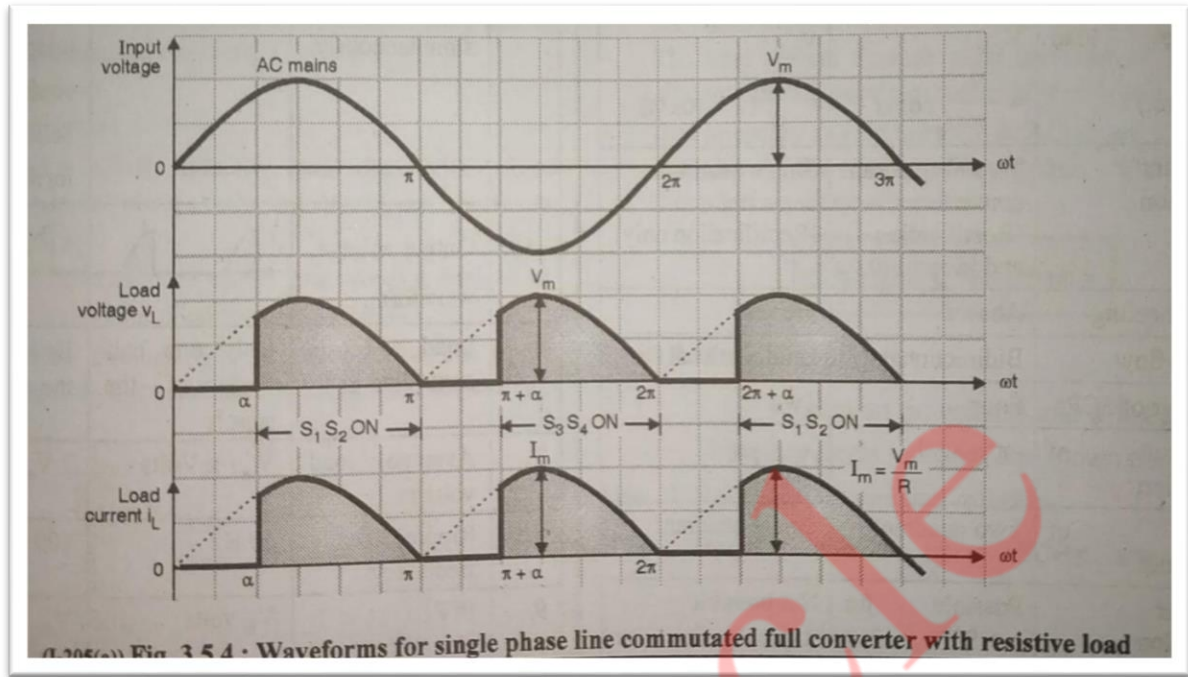

Fig 2

Q.4)b) Compare CMOS logic family with TTL logic family.

[7]

Ans:

Parameter	CMOS	TTL
Device used	N channel MOSFET and P channel MOSFET	Bipolar junction transistor
High level noise Margin	$V_{NH} = 1.45 V$	0.4 V
Low noise margin	$V_{NL} = 1.45 V$	0.4V
Noise immunity	Better than TTL	Less than CMOS
Propagation delay	105 nS	10 nS
Switching speed	Less then TTL	Faster then CMOS
Speed power product	10.5 pJ	100 pJ
Fan out	Typically 50	10
Operating areas	MOSFET are operated as switches.	Transistors are operated in saturation or cut off reasons

OUR CENTERS :

KALYAN | DOMBIVLI | THANE | NERUL | DADAR

Contact - 9136008228

Power supply	Flexible from 3 V to 15 V	Fixed equal to 5 V
--------------	---------------------------	--------------------

Q.4)c) What is servo speed? Explain working principle of servo motor. [06]

Ans: Servo speed : Servo motor is defined as the time required for the shaft to reach a specified position. Common servos have operating speeds in the range of 0,05 to 0,2.

In automatic control system it becomes necessary to compare working system with some reference.

Whatever is the error it is amplified and used to drive motors known as servo motor.

These servomotors are coupled to shaft of the output.

Thus signal error is converted into angular velocity to correct the error. Thus servo motors are not used to drive any load as usual motors.

But they are used to correct position or velocity. Depending upon type of supply used servo motors are classified

1. A.C servomotor
2. D.C servomotor

A.C servomotor

Construction of ac servomotor is shown in Fig 1

Basically it is an induction motor with two winding provided on the stator

These two windings are connected to two voltage sources which have 90° electrical phase difference. Due to this phase difference a rotating magnetic field is produced

One of the windings known as reference winding or main winding is connected to constant magnitude a.c. voltage.

The other winding is connected to voltage obtained from servo amplifier.

The rotor can be ordinary cage type rotor with aluminium bars embedded in slots and short circuited by end rings. For maximum flux linking air gap kept is minimum.

In other type of rotor a drag cup is used due to which inertia of rotating system becomes low.

This helps in reducing power consumption. The ac servomotors are used in the frequency range of 50 Hz to 400 Hz and from milliwatts power consumption to few hundred watts.

OUR CENTERS :

KALYAN | DOMBIVLI | THANE | NERUL | DADAR

Contact - 9136008228

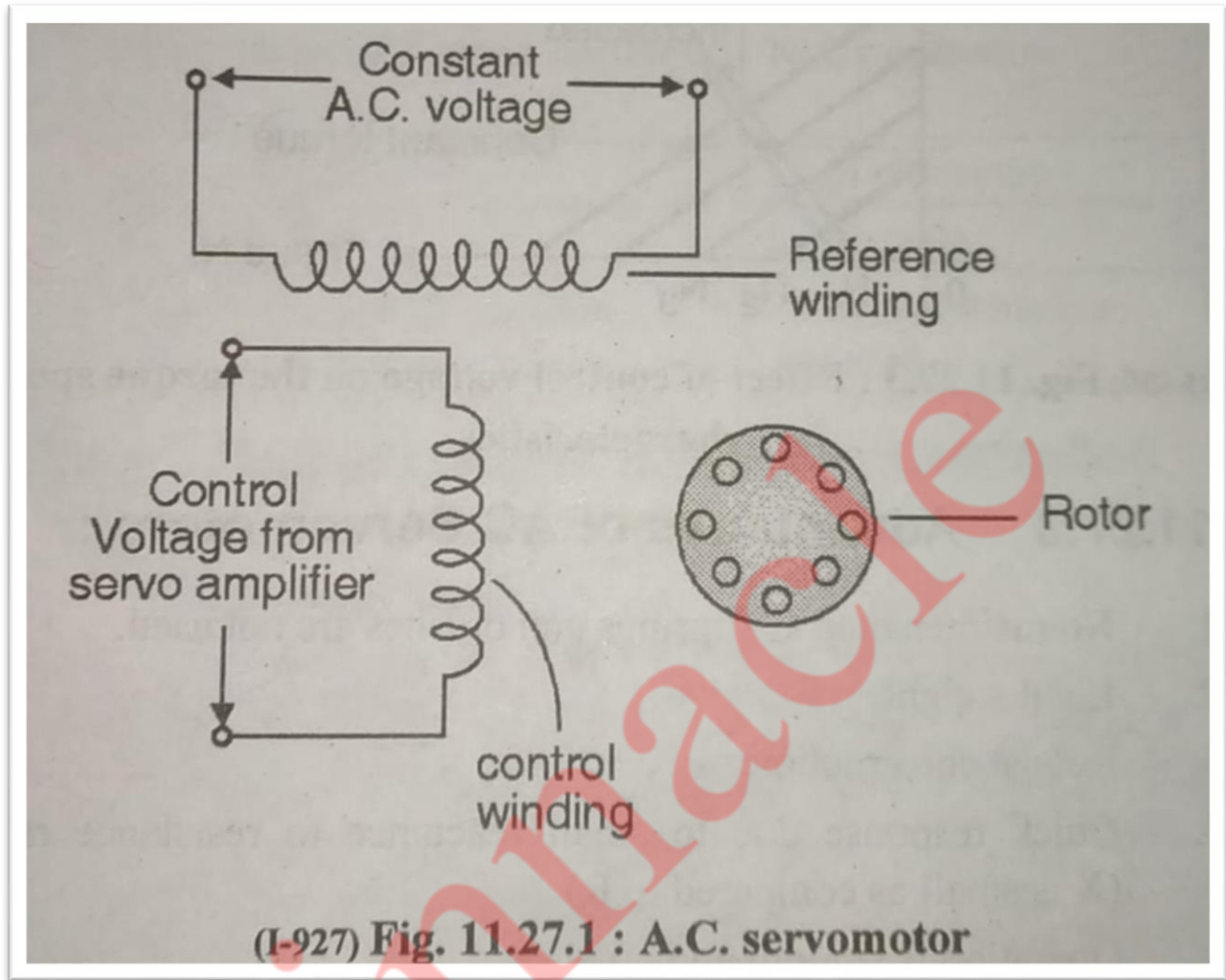

Fig 1

Applications of servomotor

- 1.Process control equipments.
- 2.Machine tools.
- 3.Instrument servos.
4. Robotics.
- 5.Sewing machine.
- 6.Process controllers.

7.AC position control applications.

8.Portable drilling machines.

Q.5)a) Derive the relation per voltage gain in inverting mode in operational amplifier and compare it with non inverting mode. [7]

Ans : The circuit diagram of inverting amplifier is Fig

The signal which is to be amplified is applied to the inverting (-) input terminal of the OP-AMP. The amplified output will be 180 degrees out of phase with the input signal.

In other words the output signal is "inverted" as shown in Fig.

Therefore this amplifier is known as the inverting amplifier. Operation of the inverting amplifier.

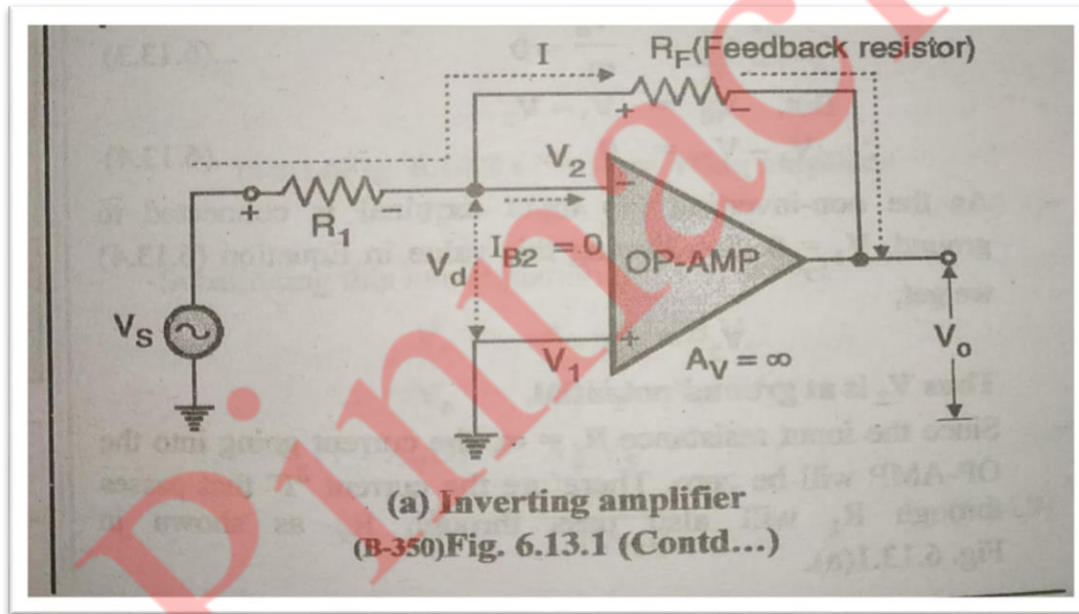

Fig

The signal to be amplified (V) has been connected to the inverting terminal via the resistance R . The other resistor R_f connected between the output and inverting input terminals is called as the feedback resistance.

It introduces a negative feedback.

The non-inverting (+) input terminal is connected to ground.

As the OP-AMP is an ideal one, its open loop voltage gain $A_y = -\infty$ and input resistance $R_i = \infty$. The negative sign for A_y is due to the inverting configuration.

OUR CENTERS :

KALYAN | DOMBIVLI | THANE | NERUL | DADAR

Contact - 9136008228

The input and output voltage waveforms are as shown in Fig. . Output is an amplified and inverted version of the input signal Vs.

Comparison of amplifier configuration.

Parameter	Inverting amplifier	Non-inverting amplifier
Voltage gain	$A_{vf} = -R_f/R_1$	$A_{vf} = 1 + R_f/R_1$
Phase relation between input and output voltages	180 ° out of phase	In phase
Value of voltage gain	Can be greater than less than or equal to unity	Always greater than or equal to unity
Input resistance	Very large	Equal to R1

Q.5)b) Draw and explain R triggering method of SCR. [7]

Ans : R Triggering

It includes one fixed resistor, variable resistor, diode, SCR (Silicon Controlled Rectifier), Load resistor.

The circuit diagram of an R Triggering is shown below (Figure 1).

Simple resistor, diode combinations trigger and control SCR over the full 180 electrical degree range, performing well at commercial temperatures.

These types of circuits operate most satisfactorily when SCRS have fairly strong gate sensitivities. Since in a scheme of this type a resistor must supply all of the gate drive required to turn on the SCR, the less sensitive the gate, the lower the resistance must be, and the greater the power rating.

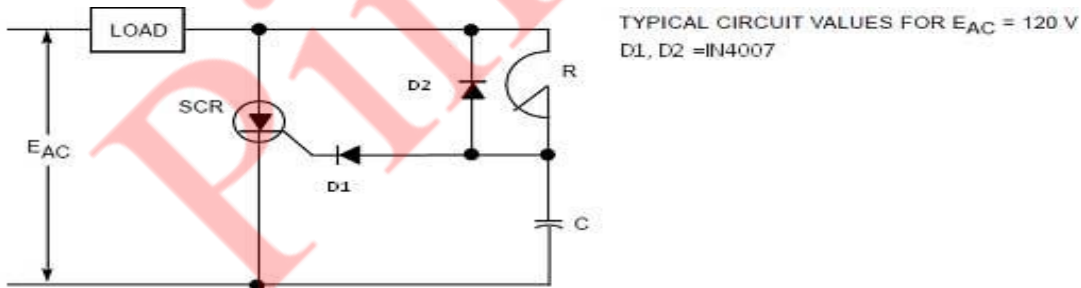

Figure 2: Simple Half-wave RC Phase Control – Circuit Schematic

Figure 1 shows a very simple variable resistance half-wave circuit. It provides phase retard from essential zero (SCR full “on”) to 90 electrical degrees of the anode voltage wave (SCR half “on”). Diode D1 blocks reverse gate voltage on the negative half-cycle of anode supply voltage.

It is necessary to rate blocking to at least the peak value of the AC supply voltage and the trigger voltage producing the gate current to fire IGF are in phase. When $E_{AC} = E_m$, at the peak of the

AC supply voltage, the SCR can still trigger with the maximum value of resistance between anode and gate.

Applications.

Used for the phase control application such as converter circuits (half & full controlled).

Q.5)c) Draw and explain astable mode of operation of IC 555. [6]

Ans : An astable multivibrator is also called as a free running multivibrator or a rectangular wave generator circuit This does not require an external trigger circuit to change the state of the output.

The "ON" and "OFF" times of the output voltage waveforms are determined by the values of resistors R and Ra along with the capacitance C.

The circuit configuration of an astable multivibrator is as shown in Fig. And the waveforms are being shown in Fig.

OUR CENTERS :

KALYAN | DOMBIVLI | THANE | NERUL | DADAR

Contact - 9136008228

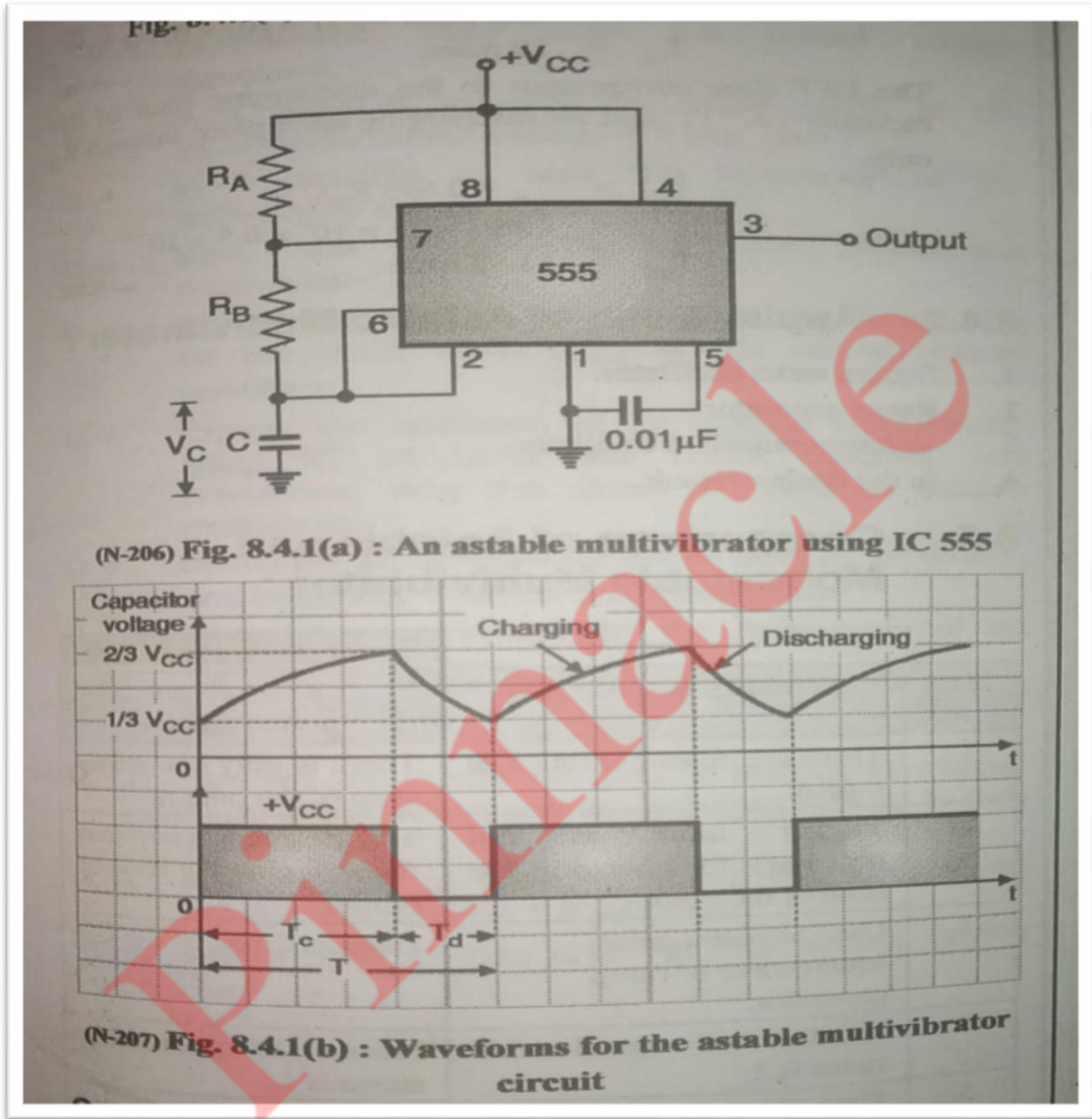

Fig 1

Operation of the circuit

Refer to the waveforms shown in Fig. 8.4.1(b). Initially when the output is high (as the voltage on C and hence voltage of pin no. 2 are less than $1/3 V_{CC}$) the capacitor starts charging through R, and Rg- After some time say "T", voltage on C reaches a level of $2/3 V_{CC}$.

As soon as $V_c = 2/3 V_{CC}$ the upper comparator output Will reset the flip-flop and the output switches to a low state. Aftersome time say "T", voltage on C reaches a level of $1/3 V_{CC}$.As soon

OUR CENTERS :

KALYAN | DOMBIVLI | THANE | NERUL | DADAR

Contact - 9136008228

as $V_c = V_2 = 1/3$ the lower comparater output will set the flip flop and output is switch to a higher state.the internal transistor T1 is turned off and the capacitor again starts charging through Ra and Rb.

Thus we obtain a rectangular voltage waveforms at the output of IC 555.

Q.6)a) Explain the application of piezo-electric actuator drive. [7]

Ans : A piezoelectric actuator control using a microcontroller involves a feedback system as shown in the figure.

The capacitance displacement sensor is used to sense the displacement of the piezoelectric actuator which works as an feedback input to the system.

The displacement sensor output is in analog form which is converted in digital form for the microcontroller to interpret.

In the system shown in figure, a ADC is deployed for this task. The microcontroller takes this input and controls the digital output accordingly. These outputs are given to a piezo driver using current pulse.

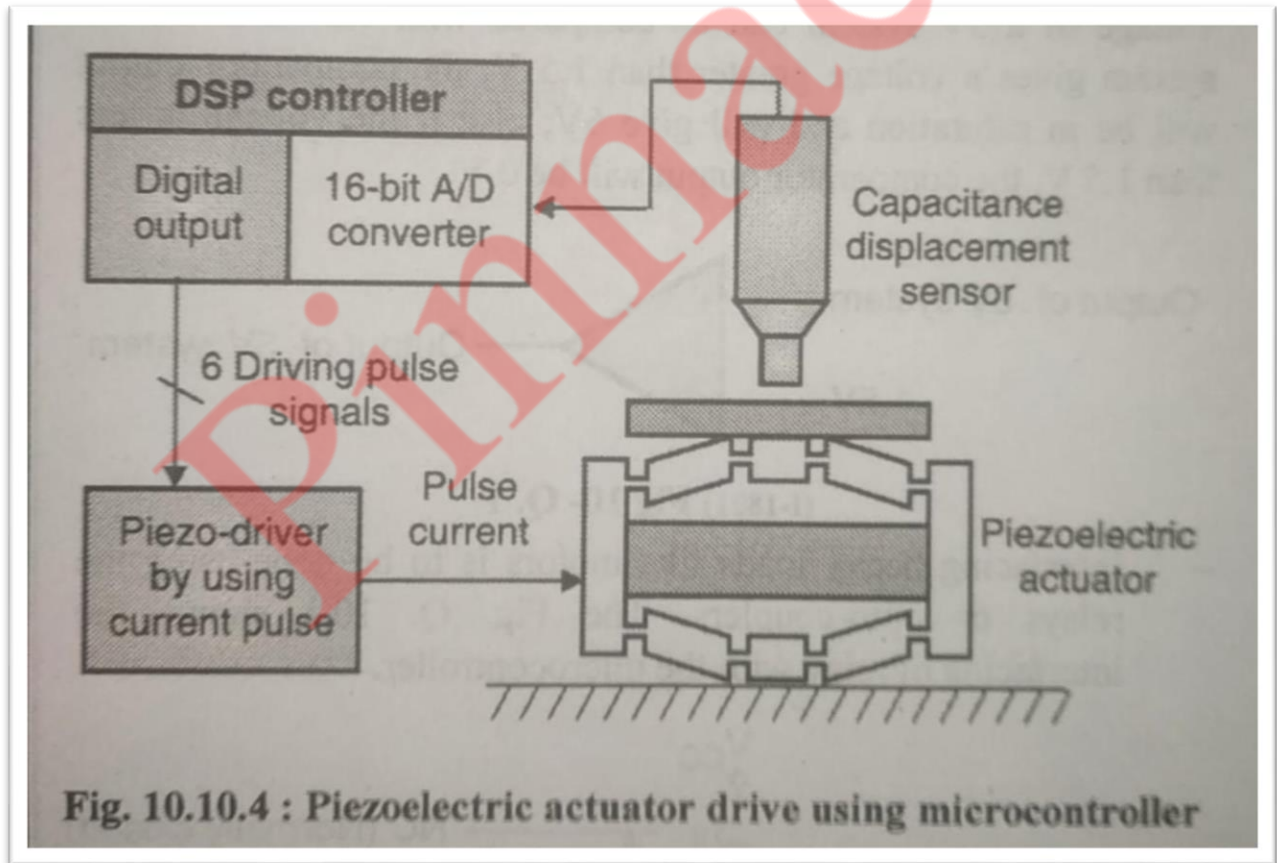
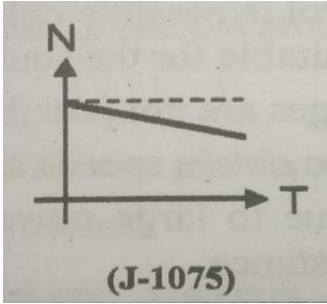
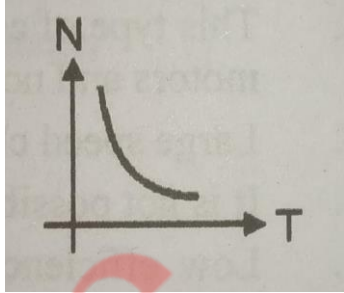

fig 1

Q.6)b) Compare DC series motor and DC shunt motor.

[7]

Ans :

Parameter	Dc shunt motor	Dc series motor
Nature of characteristics		
Relation between speed and torque	As load increases T increases and speed reduces slightly	N proportional 1/T so as load increases torque increases and speed reduces exponentially.
Connection of field winding with armature	Field is parallel with armature	Field is in series with the armature
Types of starter	3 point	4 point
Torque developed	Low	High
Reduction in speed with increasing load	Slight reduction in speed takes place	Drastic reduction in speed takes place
Starting torque	Moderately high	Very high
Applications	Machine tools	Electric trains and conveyors

Q.6)c) Explain different applications of microcontroller.

[6]

Ans: There are various applications of microcontrollers in the real time world. Some of them are discussed in this section.

Temperature measurement, speed measurement and driving and actuator are some of the applications quite common in the mechanical industry where the microcontroller is deployed.

Temperature measurement

Temperature is the most-measured process variable in industrial automation. Most commonly, a temperature sensor is used to convert temperature value to an electrical value.

Temperature Sensors are the key to read temperatures correctly and to control temperature in industrial applications.

OUR CENTERS :

KALYAN | DOMBIVLI | THANE | NERUL | DADAR

Contact - 9136008228

The LM34 are precision integrated-circuit temperature sensors, whose output voltage is linearly proportional to the Fahrenheit temperature.

The LM35 are precision integrated-circuit temperature sensors, whose output voltage is linearly proportional to the Celsius (Centigrade) temperature.

The LM34/LM35 thus has an advantage over linear temperature sensors calibrated in degrees Kelvin, as the user is not required to subtract a large constant voltage from its output to obtain convenient Fahrenheit scaling.

LM35 does not require any external calibration or trimming to provide typical accuracies of $\pm 1/4^{\circ}\text{C}$ at room temperature and $\pm 3/4^{\circ}\text{C}$ over a full -55 to $+150^{\circ}\text{C}$ temperature range.

The LM35 is rated to operate over a -55°C to $+150^{\circ}\text{C}$ temperature range.

Speed measurement using proximity sensor

Proximity sensors are used to detect objects when they come in the proximity of the sensor. A photo diode along with the light emitting diode (LED) is deployed for the task.

When the light from the LED is reflected by the object in proximity and is incident on the photo diode, the object is detected. A proximity sensor is a combination of the two in a single unit

This concept can be used to measure the speed of a motor by connecting a small object on the shaft along with the proximity sensor.

The microcontroller is then to be deployed to count the number of times the object is detected in a minute to measure the speed of the motor in revolutions per minute (rpm). The code for the microcontroller will be a simple one as in counter mode.

OUR CENTERS :

KALYAN | DOMBIVLI | THANE | NERUL | DADAR

Contact - 9136008228